

contact us



FAQs

lettucegrow.com/help



Farmstand Assembly Guide

lettucegrow.com/assembly

If you have any other questions, please reach out to us! We can't wait to help you grow!

An Initiative of:

the farm project

Copyright © 2021, Lettuce Grow®



the farmstand set-up guide

scan for video



table of contents

Where to place your Farmstand	2
What's in the box	3
Assembling the Farmstand	5
Order your seedlings	11
Adding nutrients	12
Setting up the Outdoor Smart Timer	13
Setting up the Indoor Smart Timer	15
Adjust pH & Plant seedlings	16
Maintenance & harvesting	18

where to place your farmstand

quick and easy positioning

Choose a sunny outdoor spot (or Indoors With Lights). Plants grow best with at least 6 hours of direct sunlight per day (or 14 hours with indoor growing lights). **For easier movement when full, order our dolly at lettucegrow.com/dolly.**

Note: Avoid placement next to tall trees or buildings that will limit sun exposure.

4 square feet of level space

A 2' x 2' area ensures enough space for your floor mat and unrestricted access to your plants.

power and water access

Your Farmstand needs continuous power and weekly water refills.

download the app

The Lettuce Grow app syncs to new, smart devices connected to your Farmstand, gives weekly maintenance information, and harvest guidance. Download it for the ultimate hassle-free growing experience!



download the lettuce grow app
for growing tips & reminders!



03

what's in the box?

Before starting, make sure you have all of your components, including the Glow Rings if you're growing indoors. If using Glow Rings, jump to page 8 for assembly instructions.



plant levels

If you ordered a 30- or 36-Plant Farmstand, your extension kit (levels + pipes) will ship separately.



lid



gasket



smart timer



grow cup (x20)



nutrients a & b



tank



fill port cover



pvc pipes



pipe coupler (x2)



water diffuser



power supply



tsp scoop (x2)



ph test kit



pump + pump fitting +rubber suction cups



pipette



ph down

04

05

assembling the farmstand: pump and tank



1 If you have a mat, lay it where your Farmstand will be placed and center the Tank on top.

2 Locate your Pump and flip the dial on the lower-back of the Pump towards the right ('+ sign') to ensure the opening is in the correct position. Attach the suction cups to the bottom of the Pump.

3 **(*Fig.1)** Screw the Pump Fitting into the Pump opening. Next, attach the pipes in the following order (as shown in the illustration): one pipe, then add a coupler, followed by the remaining pipe. **Be sure all connections are pushed in tightly.**

4 Firmly press the pump in the center of the tank to secure the suction cups. Run the pump's electrical cord through the opening on the side of your tank.

5 Locate the Power Supply and set it on the ground next to the Tank.

Note: For 12- and 18-plant Farmstands, place the short pipe on top of the longer pipe.

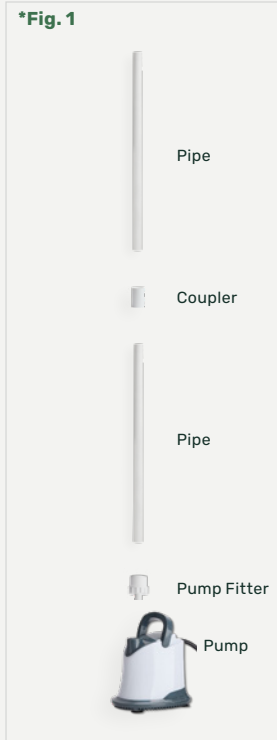

06

assembling the farmstand: pump and tank

6 Push the pump's electrical cord into the opening on the bottom of the gasket that doesn't have a small plug installed. The second opening is intended for lights produced by Lettuce Grow. If not in use, leave the plug in the second opening to prevent water leaks.

Make sure there is enough slack in the Power Supply cord to make a U-shape in side the tank.

Line up the groove on the gasket with the edge of the tank opening and pop the gasket into place. It will fit very snugly and you may need to bend it to pop it into place!

Snap the tank cap into place over the gasket.

Add water to your tank until it is filled to ~3/4 full.

For easier movement when full, order our dolly at lettucegrow.com/dolly.

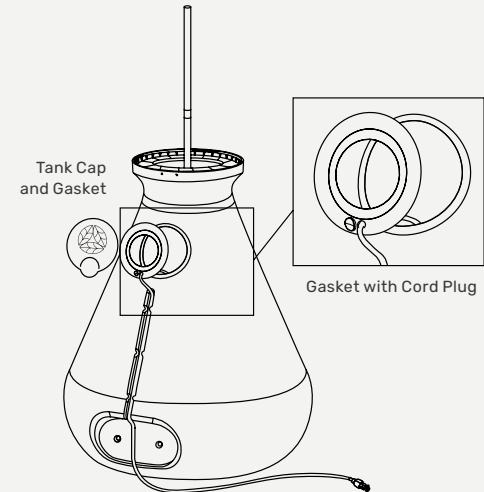

07

assembling the farmstand: attaching the modules

7

Place the first growing level over the pipe and slide it down to the tank with the seedling port holes on the bottom.

8

Align the growing level so that it sets into the groove, then twist to lock in place. The circle icon should line up with the open lock icon before twisting. The lock and circle icon should line up once locked.

Note: If you are using Glow Rings (LED lights), skip ahead to Page 8 now for instructions.

Repeat for all additional levels.

Locate the water diffuser and place it on top of the pipe as pictured in the diagram to the right. Then place the Farmstand lid on the top level and lock it into place.

Want to add more levels? You can add more levels up to a maximum of 6 (36 plants) by purchasing an extension kit on our website: lettucegrow.com/products/extension-kit

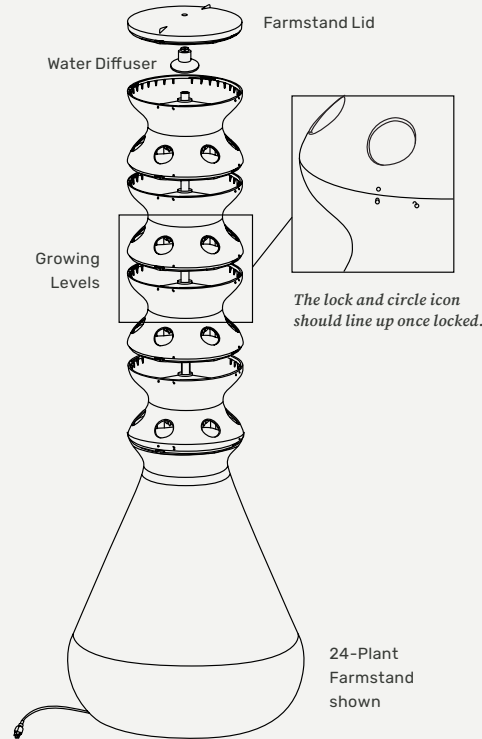

Refer to page 14 of this guide for instructions on how to empty your tank. DO NOT move the Farmstand when it is full unless you have it on a dolly.

08

assembling the farmstand: with glow rings

1

If you already have a Farmstand, begin by unplugging your Farmstand, removing the lid, diffuser cap, fill port cap, gasket, and all modules except for the first one.

If you are setting up a new Farmstand follow the Farmstand Assembly guide and add just one module.

For all indoor Farmstands we recommend placing it on a mat to avoid water dripping off plants and onto the floor.

2

Set aside your top single-cabled Glow Ring (you'll use this last). The two ends of the dual-cabled rings will arrive screwed together. You will need to unscrew them in order to connect them to the rings above and below. Pass the connector side of the power supply cord through the fill port opening and up through the center module hole. Make sure the cord goes down before up, creating slack in the cord.

3

Attach the first dual-cabled Glow Ring to the top of the first module. Once attached, connect the ring cable to the power supply cable. The cap should be screwed until it meets the tip of the arrow. A tight connection will protect from water damage and is important for the longevity of the lights.

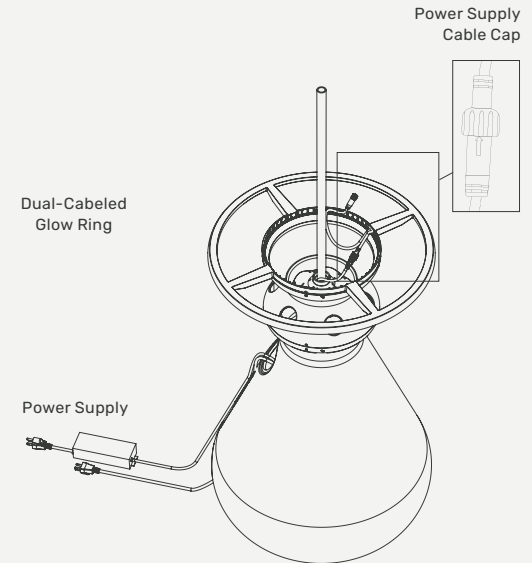

09

assembling the farmstand: with glow rings

4 Get your next module level ready and feed the longer, non-connected Glow Ring cable up and through the center hole before you attach the second module to the first Glow Ring. Hint: It's easier to feed the cable through the module center before locking the module in place.

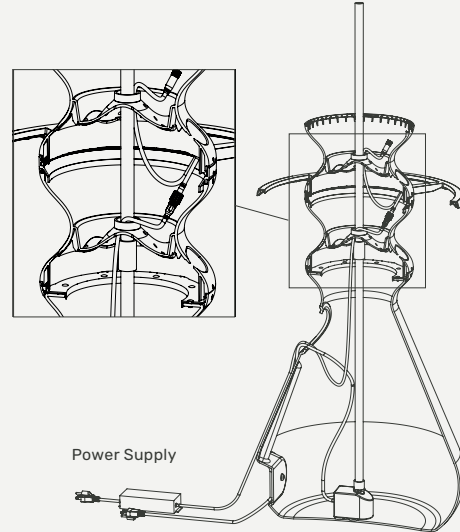

5 Repeat step 3 & 4 for each dual-cabled Glow Ring and module, and save the top single-cabled Glow Ring for last. The short connector cords should always connect to the lower ring, and the longer connector cords should always thread up to the ring above.

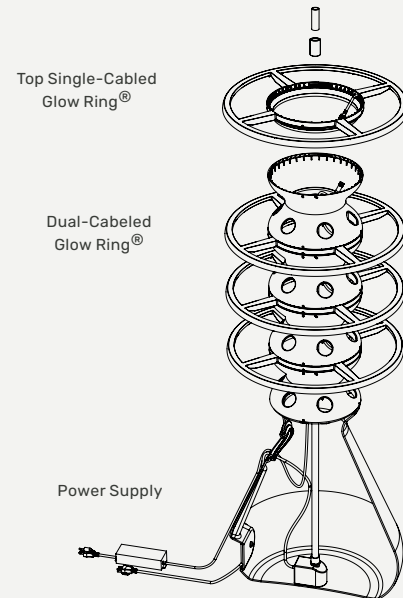

6 Attach the single-cabled Glow Ring to the top module and connect the long cable from the ring below to the single cable connection. There should not be an unconnected cable once all Glow Rings are installed. Any unconnected cables will cause damage to the device.

10

assembling the farmstand: with glow rings

7 The small pipe extender and coupler (received in the Glow Rings box) should be placed at the top of the pipe stack, closest to the diffuser. Note: Pipe extensions and couplers are only needed for 24-, 30- and 36-plant Farmstands. 36-plant Farmstands will need two pipe extensions and two couplers.

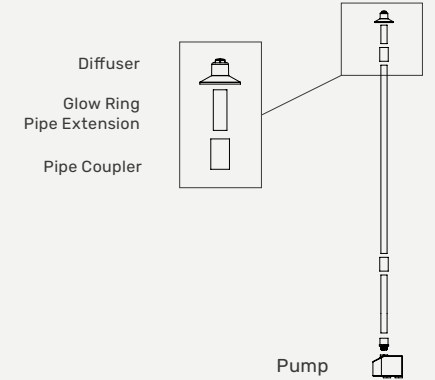

8 Remember to put the diffuser cap on and then the lid can attach to the top Glow Ring.

9 After the Glow Rings are assembled, run the power supply cord through the second hole in the fill port gasket. If there is a temporary plug in that hole you will need to remove it. When you lock the gasket into place make sure there is enough slack so that the power supply cord drops down into the Farmstand's tank before it goes back up and connects to the first Glow Ring, as shown in the graphic to the right. If the gasket that came with your Farmstand does not have two holes, visit lettucegrow.com/help for a replacement.

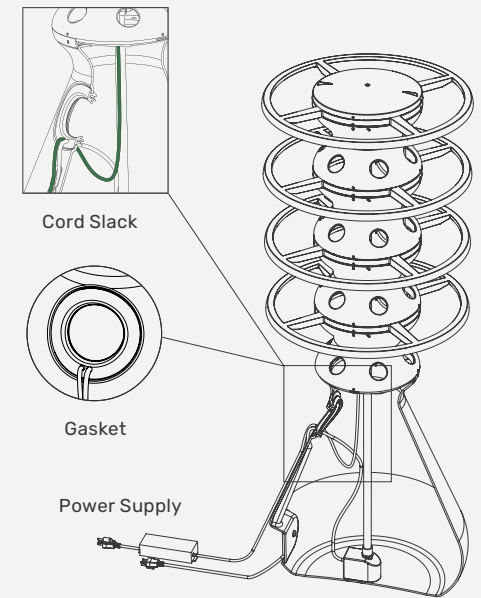

order your seedlings

Now that your Farmstand is set up, it's time to order your seedlings!

Now that your Farmstand is set up, it's time to pick the plants for your first growing season. Scan the QR code below or visit: lettucegrow.com/get-plants

This page will walk you through the quick process of selecting your seedlings based on where you purchased your Farmstand.

Note: our LIVE seedlings must be unboxed immediately upon arrival to prevent them from drying out, so please ensure your Farmstand is fully set up before proceeding. We are not responsible for replacements due to neglect.

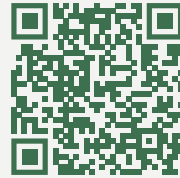

scan to select & order plants

Need support? Visit lettucegrow.com/help

adding nutrients

Wait to proceed until your plants have arrived.

fill up your tank

- 1 If you haven't already, fill water in your Farmstand by removing the Fill Port Cover and filling until the tank is approximately $\frac{3}{4}$ full.

adding nutrients

- 1 (*Fig 12) Start by removing the Fill Port Cover.
 - 2 Add warm water to a lidded jar and add 4 TBSP of Nutrient A. Secure the lid and shake vigorously until dissolved. Pour contents into the Tank.
 - 3 Repeat with Nutrient B.
 - 4 Top off the water level in the Tank.
- NOTE: The above dosage is for a fresh tank of water. For weekly maintenance, add nutrients only if water is being added to reach the fill line. If no water is being added, there is no need to add more nutrients.**
- Your weekly dosage can be found in the Lettuce Grow app or by scanning the QR code on your nutrients. It will vary each season.



scan for video

*Fig.11

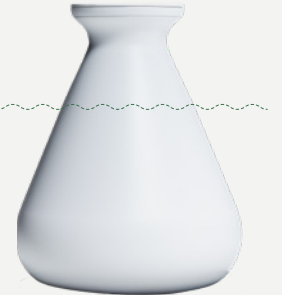

approximately $\frac{3}{4}$ full



*Fig.12

13

setting up the outdoor farmstand smart timer

We recommend using the Smart Timer with the Lettuce Grow App for our most up-to-date timer recommendations and full control of the settings. If you don't have access to wifi, the Smart Timer can also be configured manually.



scan for video

with the lettuce grow app

- 1 Plug your Farmstand into the power supply box, and the power supply cord into your Outdoor Smart Timer. Plug the smart timer into your power outlet.
- 2 Go to the home screen in your Lettuce Grow App, and scroll down to see your Farmstand. (If you don't have one, please add it now).
- 3 Click "Connect a Smart Timer", and follow the instructions on screen to connect your account via email.
- 4 Verify that you have enabled WiFi, Bluetooth and Location Services. You will need 2.4 GHz Wifi (or mixed 2.4 GHz + 5G frequency).
- 5 Press the button on your outdoor smart timer for approx. 15 seconds. The app will search for your smart timer. You will hear a click and the light will start blinking blue. Follow the instructions on screen to complete set up.

- 6 After completing setup, you may adjust the 'Smart Timer Settings' from the home screen of the Lettuce Grow app. (If you don't see your timer connected, reload the app.)

From here, you can adjust the water cycle settings according to the temperature (Cool, Warm, Hot), run a cleaning cycle, run a pump test, or even manually adjust your water cycles.

manual controls

- Hold 15s: Reset + Pair: factory reset and pairing mode (LED blinks blue)
- Hold 5s: DayStart: sets "daytime" to the current time (color mode unchanged).
- Double press: Pump Test: runs pump for 5 minutes, stops automatically (or with one press), then returns to previous mode.
- Quick press: Temperature modes (Cool, Warm, Hot). If in User-Defined, first press returns to Warm.

14

setting up the indoor farmstand smart timer

We recommend using the Smart Timer with the Lettuce Grow App for our most up-to-date timer recommendations and full control of the settings. If you don't have access to wifi, the Smart Timer can also be configured manually.



scan for video

with the lettuce grow app

- 1 Plug the Smart Timer into a working outlet. Some force may be necessary.
- 2 Download the Lettuce Grow app.
- 3 Open the app and login in with your account information or signup (if you purchased in person.)
- 4 If you purchased your system in person, "Add Your Farmstand"; click "Connect a Smart Timer" and follow the instructions.
- 5 (*Fig.13) Plug the lights into the left outlet (1) and the pump into the right outlet (2).

without the lettuce grow app

- 1 Plug the Smart Timer into a working outlet. Some force may be necessary.
- 2 Plug the lights into the left outlet (1) and the pump into the right outlet (2).
- 3 The timer will automatically set the start of the 14-hour Day cycle when you initially turn it on. We recommend plugging in your Smart Timer when you want the Day cycle to begin.
- 4 To select the current time as the start of the 14 hour daytime period press and hold the top button (3) for 5 seconds, or simply unplug and replug the Smart Timer

15

setting up the indoor farmstand smart timer

default app settings

We recommend mimicking the natural outdoor light cycle, but you can make adjustments as

DAY (8am - 10pm)	Lights (On)	Pump
	14 hours	2 mins on/ 58 mins off
NIGHT (10pm - 8am)	Lights (Off)	Pump
	10 hours	2 mins on/ 2 hrs 58 mins off



optional functionality

Pump Test

This feature allows you to run the pump for short periods of time. Press the bottom button **(4)** to run a 2-minute pump test. When the test starts, the light on the top button **(3)** will be solid while the light on the bottom button **(4)** will blink.

Timer Snooze

Need a break? Pause the Nook's Pump and Lights for 90 minutes by quickly pressing the top button **(3)**. The regular cycle will continue once the snooze is finished.



scan for faq's

16

adjusting ph with the ph kit



scan for video

testing ph

- 1** Your pump (and lights if applicable) may automatically turn on according to time of day. If this is not the case, run a pump test. Let your pump run for 2 minutes before proceeding with testing your pH.
- 2** Open the Fill Port Cover and use the Pipette to collect water from your tank.
- 3** Fill the small pH Test bottle with 5 mL of water from your Farmstand. Add 5 drops of pH Test Solution to the water and place the cap on the bottle.
- 4** Give it a swish and match your water to the color chart included with your pH Test Kit. The ideal range is 5.5–6.2. **It is important to check your pH level each week as it will increase over time.**



adjusting ph

- 1** **If your pH is above 6.2**, add 10 mL of liquid pH Down to the tank using the Pipette. Rinse the Test Kit bottle and pipette with fresh water, let the pump run for 5 minutes to make sure water in the tank is well mixed, and then re-test. If you have hard water, it is common to add more pH Down until your water is balanced.

plant your seedlings

1

Place each seedling in an open Grow Cup on your Farmstand as shown in ***Fig. 10**. Make sure the plant is pushed all the way down into the Grow Cup, so it gets watered properly.

2

Our seedling orders arrive with Plant ID Labels that fit on the tab of each Cup. Just fold the label and push the circle through the tab on the Grow Cup.

NOTE: Don't worry if your plants look a little tired in their first week—it's totally normal after shipping. Give them a little time to settle in, and by week 2, you'll start to see fresh new growth as they perk up and get to work.



scan for video



what's next

weekly maintenance

Once your seedlings are planted, there's not much to do at first—enjoy watching them settle in! **For the first two weeks of growing you don't need to add water or nutrients just yet.**

On day 14, start checking in weekly with the following steps to keep things running smoothly:

- Top off the water to the max fill line.
- Only add Nutrients A & B if you've added at least 1 gallon of water; reference the Lettuce Grow app or scan the nutrients bag for your weekly dosage amount.
- Test and adjust the pH
- Add new seedlings or a Plant Cork into any open ports to keep your harvest going strong and avoid algae growth inside your system

pro tips

Be sure to scout your plants for pests & treat regularly. Want more info on this topic? Visit our FAQs to learn more:



scan for pest resources



scan for video



what's next

two ways to harvest

1

Cut and Come Again (Partial Harvest):

By week 3, many plants will be ready for their first light harvest using the 'Cut and Come Again' method. Just be sure to harvest no more than one-third of the leaves at a time—this keeps your plants thriving and producing again and again.



2

Full Plant Harvest:

For greens like lettuces and bok choy, we recommend harvesting the full plant. This helps to prevent pests, keeps your Farmstand clean, and allows you to grow more plants! Simply pull the grow cup out of the Farmstand, remove the roots (and compost them), and rinse and re-use the Grow Cup for your next seedling refill. When it's time for a 'Full Plant Harvest,' you'll be notified in the app and can also check the 'Replace By' date on the Plant ID Label.



get cooking

Looking for ways to use your harvest? We've got you covered with **200+** **chef-approved recipes** on our site—designed to help you turn fresh-picked produce into meals you'll love. lettucegrow.com/blogs/recipes



scan for recipes

what's next

cleaning the farmstand

To keep both your system and plants happy and healthy, **we recommend a "Reset" AKA emptying and refreshing the tank once every 3 months.** Water chemistry is the key to growing healthy plants, and a clean tank is the first step to success.

For easier, automated resets, shop our Cleaning Kit at lettucegrow.com/cleaning-kit



don't forget to tag us **@lettucegrow** on social!
we can't wait to see what you whip up with your fresh harvests.



scan for video